



SUPERLIFT®

S U S P E N S I O N

2007-2016 JEEP JK WRANLER REFLEX CONTROL ARM INSTALLATION INSTRUCTIONS

THANK YOU FOR CHOOSING SUPERLIFT FOR ALL YOUR SUSPENSION NEEDS!

INTRODUCTION

Installation requires a professional mechanic. The overall vehicle must be in excellent working condition; repair or replace all worn parts.

Read instructions several times before starting. Be sure you have all needed parts and know where they install. Read each step completely as you go.

NOTES:

- Prior to beginning the installation, check all parts and hardware in the box with the parts list below. If you find a packaging error, contact Superlift® directly. Do not contact the dealer where the system was originally purchased. You will need the control number from each box when calling; this number is located at the bottom of the part number label and to the right of the bar code.
- A precision steering alignment, including the centering of the steering wheel, is required in order for the vehicle's Electronic Stability Program to function properly. Using "all laser" alignment equipment is recommended.
- An arrow on diagrams indicates which direction is toward the front of the vehicle.
- A foot-pound torque reading is given in parenthesis () after each appropriate fastener.
- Prior to drilling or cutting, check behind the surface being worked on for any wires, lines, or hoses that could be damaged. After drilling, file smooth any burrs and sharp edges.
- Paint or undercoat all exposed metal surfaces.
- Prior to attaching components, be sure all mating surfaces are free of grit, grease, excessive undercoating, etc.
- A factory service manual should be on hand for reference.
- Use the check-off box "☐" found at each step to help you keep your place. Two "☐☐" denotes that one check-off box is for the driver side and one is for the passenger side. Unless otherwise noted, always start with the driver side.

THESE INSTRUCTIONS DETAIL THE STEPS FOR ALL CONTROL ARMS. IF BOTH FRONT AND REAR CONTROL ARMS OR FRONT CONTROL ARMS ONLY WERE PURCHASED, PROCEED TO STEPS BELOW. IF REAR ONLY WERE PURCHASED, PROCEED TO STEPS IN “REAR PROCEDURES”.

FRONT PROCEDURES

NOTE: Save all factory components and hardware for reuse, unless noted.

1) PREPARE VEHICLE...

- Place vehicle in neutral. Raise front of vehicle with a jack and secure a jack stand beneath each frame rail, behind the front / lower control arms. Ease the frame down onto the stands, place transmission in low gear or “park”, and chock rear tires. Remove front tires.

- Position a jack so that it supports, but does not raise, the front axle.

IF THE LOWER CONTROL ARMS WERE THE ONLY FRONT CONTROL ARMS PURCHASED, PROCEED TO STEP 4.

2) REFLEX UPPER CONTROL ARM PREPARATION...

- Reflex control arm length, measured from center of eye-to-center of eye, must measure 18-1/2”; verify that both control arms are set to this length. If adjustment is necessary, rotate the threaded end accordingly.

3) REFLEX UPPER CONTROL ARM INSTALLATION...

NOTE: Perform the steps in step 3 one side at a time, starting on the passenger side. Not all steps are required on driver side.

- Loosen, but do not remove, the single bolt that connects the passenger side motor mount to frame.

- Remove the three nuts that secure the transmission isolator-to-transmission crossmember.

- Position a jack with a block of wood under the oil pan. Raise the jack so that the engine will tilt / rotate towards the driver side of vehicle. This will allow clearance needed to remove the control arm bolt at the frame on the passenger side without removing the exhaust.

- Remove the bolt from the factory control arm’s axle and frame ends then remove control arm.

- Attach the bushing end of the Reflex control arm-to-frame using the factory bolt and tab nut. Do not tighten yet.

- Attach the bracket end of the Reflex control arm-to-axle using the factory hardware. Do not tighten yet.

- Lower the jack supporting the oil pan.

- Tighten the motor mount hardware on the passenger side (80).

Reinstall the three nuts that secure the transmission isolator-to-transmission crossmember (40).

Repeat appropriate steps for driver side control arm installation. On this side it is not necessary to loosen motor and transmission mounts, nor elevate the engine; simply remove the factory control arm then install the Reflex unit. Again, do not tighten any hardware at this time.

IF THE UPPER CONTROL ARMS WERE THE ONLY FRONT CONTROL ARMS PURCHASED, PROCEED TO STEP 5.

4) REFLEX LOWER CONTROL ARM INSTALLATION...

NOTE: Perform the steps in step 4 one side at a time

- Remove the factory front lower control arm.
- [Illustration 1] Using a grinder, clearance the lower control arm mounts at the axle, as shown. Not much trimming is required; simply remove the mount's top radius.
- When installing the Reflex control arms they do need to be orientated correctly. The bend in the arm should point up when installed. Attach the Reflex control arm-to-frame using the factory hardware; install the bolt from the outside. Do not tighten the control arm bolt yet.
- One side at a time, remove the rear knock-outs that change the opening from a square hole to a slotted hole. A special tool is available for this, or use a die grinder with a small cutting wheel.

[Illustration 2] Reconnect lower control arms to the axle using the supplied cam bolts (#77-5704A), installed from the outside. Rotate the cams to their "most positive" setting, so that the front axle is shifted as far forward as possible (the bolt head will be in its most rearward position). Snug-up the bolts; do not fully tighten at this time.

5) TIRES / WHEELS... [Illustration 3]

Tighten the lug nuts (115) in the sequence shown.

WARNING: When the tires / wheels are installed, always check for and remove any corrosion, dirt, or foreign material on the wheel mounting surface, or anything that contacts the wheel mounting surface (hub,

Illustration 1

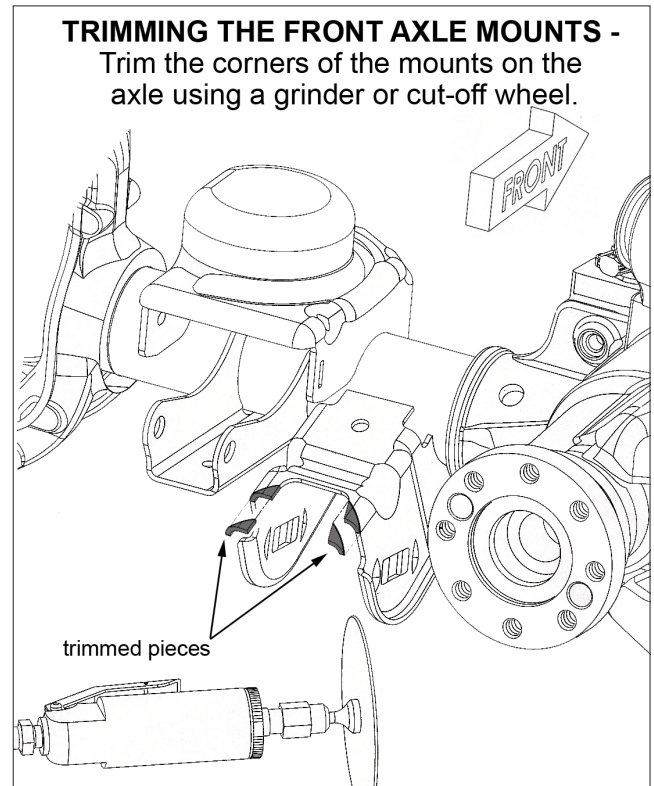
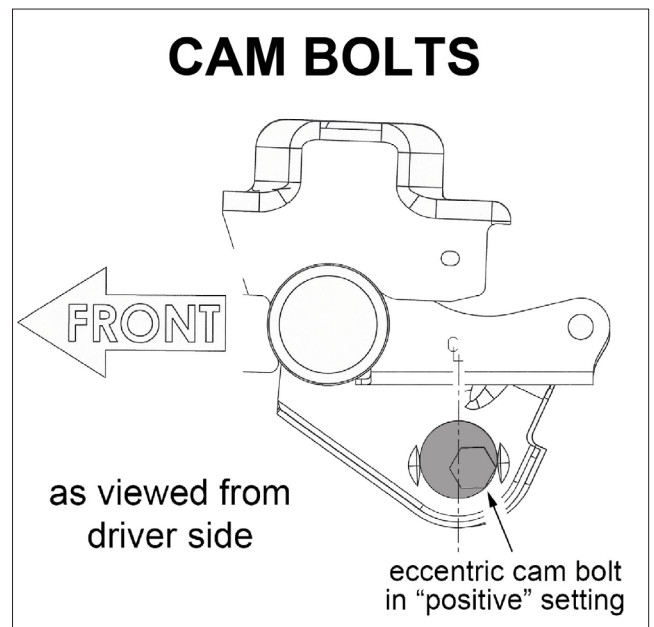

Illustration 2



rotor, etc.). Installing wheels without the proper metal-to-metal contact at the wheel mounting surfaces can cause the lug nuts to loosen and the wheel to come off while the vehicle is in motion.

WARNING: Retighten lug nuts at 500 miles after any wheel change, or anytime the lug nuts are loosened. Failure to do so could cause wheels to come off while vehicle is in motion.

6) INITIAL CLEARANCE CHECK, FRONT...

With the vehicle still on jack stands, and the suspension “hanging” at full extension travel, cycle steering lock-to-lock and check all components for proper operation and clearances. Pay special attention to the clearance between the tires / wheels and brake hoses, wiring, driveshaft-to-crossmember, etc.

Lower vehicle to the floor. Final tightening and adjustments to the front suspension will take place once rear lift is completed.

IF NO REAR CONTROL ARMS WERE PURCHASED, PROCEED TO “FINAL PROCEDURES”.

REAR PROCEDURES

7) PREPARE VEHICLE...

Place vehicle in neutral. Raise rear of vehicle with a jack and secure a jack stand beneath each frame rail, just ahead of the rear / lower control arms. Ease the frame down onto the stands, place transmission in low gear or “park”, and chock front tires. Remove rear tires.

Position a jack so that it supports, but does not raise, the rear axle.

IF THE LOWER CONTROL ARMS WERE THE ONLY REAR CONTROL ARMS PURCHASED, PROCEED TO STEP 9.

8) REFLEX UPPER CONTROL ARM INSTALLATION...

NOTE: Perform the steps in step 8 one side at a time.

Remove the bolt from the factory control arm’s axle and frame ends then remove control arm.

Install the Reflex arm with the bend pointing up and the short end of the arm to the frame; secure using the factory hardware. Do not tighten at this time.

IF THE UPPER CONTROL ARMS WERE THE ONLY REAR CONTROL ARMS PURCHASED, PROCEED TO STEP 11.

9) REFLEX LOWER CONTROL ARM PREPARATION...

Reflex control arm length, measured from center of eye-to-center of eye, must measure 19-3/4”; verify that both control arms are set to this length. If adjustment is necessary, rotate the threaded end accordingly.

Illustration 3

LUG NUT TORQUE SEQUENCE
Follow the pattern shown to torque the lug nuts.

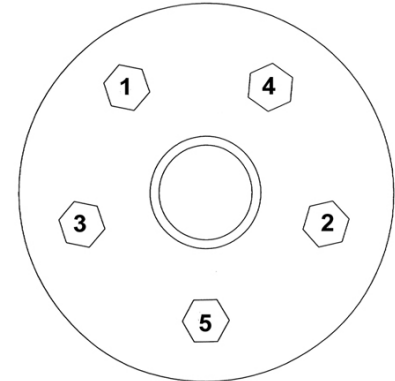

10) REFLEX LOWER CONTROL ARM INSTALLATION...

NOTE: Perform the steps in step 10 one side at a time.

- Remove the bolt from the factory control arm's axle and frame ends then remove control arm.
- Install the Reflex arm with the adjustable end at the frame mount using the factory hardware. Do not tighten at this time.

11) TIRES / WHEELS...

- Tighten the lug nuts (115) in the sequence shown in illustration 3.

WARNING: When the tires / wheels are installed, always check for and remove any corrosion, dirt, or foreign material on the wheel mounting surface, or anything that contacts the wheel mounting surface (hub, rotor, etc.). Installing wheels without the proper metal-to-metal contact at the wheel mounting surfaces can cause the lug nuts to loosen and the wheel to come off while the vehicle is in motion.

WARNING: Retighten lug nuts at 500 miles after any wheel change, or anytime the lug nuts are loosened. Failure to do so could cause wheels to come off while vehicle is in motion.

FINAL PROCEDURES**12) INITIAL CLEARANCE CHECK, REAR...**

- With the vehicle still on jack stands, and the suspension "hanging" at full extension travel, check all components for proper operation and clearances. Pay special attention to clearance between the tires / wheels and brake hoses, driveshaft, etc.

13) HARDWARE TIGHTENING SEQUENCE...

- Remove jack stands and lower vehicle to the floor. The suspension is now supporting vehicle weight.

- All rear control arms-to-frame and axle (125).

- Front / lower control arms-to-frame and axle (125). NOTE: Be sure that eccentric cam bolts are positioned as per installation step.

- Front / upper control arms-to-frame and axle (75).

14) FINAL CLEARANCE and TORQUE CHECK...

- Cycle steering lock-to-lock and inspect the tires / wheels, and the steering, suspension, and brake systems for proper operation, tightness and adequate clearance.

15) ALIGNMENT...

- Realign vehicle to factory specifications. A precise alignment, including the centering of the steering wheel, is required in order for the vehicle's Electronic Stability Program to function properly. A laser alignment is recommended.

16) SUPERLIFT WARNING DECAL...

- The WARNING TO DRIVER decal installs on the inside of the vehicle within the driver's view.

Prior to installation, pre-clean the surface with the supplied alcohol cleaning pad.

17) SUPERLIFT BADGES...

- This kit is packaged with a Superlift badge. Prior to installation, use the supplied alcohol pad to eliminate all soap and or other non-adhering residues that may impair adhesion, thoroughly clean the entire area of placement.

- Remove the adhesive back and place small badge in the desired location. The adhesive on our badges is pressure sensitive and must be applied using pressure on all areas of the graphic. Like any PSA (pressure sensitive adhesive), it can take up to 72 hours for the adhesive to fully cure. Once the badge is in place do not peel it up, this will diminish the adhesive properties and could result in damaging the badge itself

- To keep your Superlift badge in "like new" appearance keep the badge free/clear of solvents and chemicals that could cause the adhesive to dry or dissolve. This includes gasoline, diesel fuel, paint thinner, and alcohol. Soap and water is all that is needed for cleaning. Degreasers can be used sparingly and hand wiped/applied if needed, although not suggested.

Superlift, LLC, Limited Lifetime Warranty

What is covered? Subject to the terms below, Superlift® will repair or replace its products found defective in materials or workmanship for so long as the original purchaser owns the vehicle on which the product was originally installed. Your warrantor is Superlift, LLC, doing business as Superlift® Suspension Systems ("Superlift®").

What is not covered? Your Superlift® Limited Warranty does not cover products Superlift® determines to have been damaged by or subjected to:

- Alteration, modification or failure to maintain.

- Normal wear and tear (bushings, rod ends, etc.). Scratches or defects in product finishes (powder coating, plating, etc.).

- Damage to, or resulting from, the vehicle's electronic stability system, related components or other vehicle systems.

- Racing or other vehicle competitions or contests. Accidents, impact by rocks, trees, obstacles or other aspects of the environment.

- Theft, vandalism or other intentional damage.

Remedy Limited to Repair or Replacement. The exclusive remedy provided hereunder shall, upon Superlift's inspection and at Superlift's option, be either repair or replacement of the product covered under this Limited Warranty. Customers requesting warranty consideration should contact Superlift® by phone (1-800-551-4955) to obtain a Returned Goods Authorization number. All removal, shipping and installation costs are customer's responsibility.

If a replacement part is needed before the Superlift® part in question can be returned, you must first purchase the replacement part. Then, if the part in question is deemed warrantable, you will be credited / refunded.

Other Limitations - Exclusion of Damages - Your Rights Under State Law

- Neither Superlift® nor your independent Superlift® dealer are responsible for any time loss, rental costs, or for any incidental, consequential or other damages you may have.
- This Limited Warranty gives you specific rights, and this is the only warranty Superlift® makes in connection with your product purchase. You may also have other rights that vary from state to state. For example, while all implied warranties are disclaimed herein, any implied warranty required by law is limited to the terms of our Limited Lifetime Warranty as described above. Some states do not allow limitations of how long an implied warranty lasts and / or do not allow the exclusion or limitation of incidental or consequential damages, so the limitations and exclusions herein may not apply to you. Superlift® neither assumes nor authorizes any retailer or other person or entity to assume for it any other obligation or liability in connection with this product or Limited Warranty.

Superlift, LLC, Satisfaction Guarantee

We want you to purchase our product with confidence and be 100% satisfied with the end result. If you have any legitimate issue, and Superlift® cannot rectify it to your satisfaction, Superlift® will take back the Superlift® brand product and refund the customer 100% of the product purchase price.

The details:

- Offer valid to the original retail consumer for six months after product purchase.
- May require a Superlift® dealer's participation in order to assist in "troubleshooting" the issue.
- Any costs related to labor, freight, incidental or consequential are not refunded.
- Refund will not exceed Superlift's® published retail price.

Important Product Use and Safety Information / Warnings

As a general rule, the taller a vehicle is, the easier it will roll over. Offset, as much as possible, what is lost in rollover resistance by increasing tire track width. In other words, go "wide" as you go "tall"; always use as wide a tire and wheel combination as feasible to enhance vehicle stability. We strongly recommend, because of rollover possibility, that the vehicle be equipped with a functional roll bar and cage system. Seat belts and shoulder harnesses should be worn at all times. Avoid situations where a side rollover may occur.

Generally, braking performance and capabilities are decreased when significantly larger / heavier tires and wheels are used. Take this into consideration while driving. Also, changing axle gear ratios or using tires that are taller or shorter than factory height will cause an erroneous speedometer reading. On vehicles equipped with an electronic speedometer, the speed signal impacts other important functions as well. Speedometer recalibration for both mechanical and electronic types is highly recommended.

Do not add, alter, or fabricate any factory or aftermarket parts to increase vehicle height over the intended height of the Superlift® product purchased. Mixing component brands is not recommended.

SUPERLIFT SUSPENSION

300 Huey Lenard Loop Rd.
West Monroe, Louisiana 71292
Phone: (318) 397-3000
Sales / Tech: (800) 551-4955
Fax: (318) 397-3040
www.superlift.com