



300 HUEY LENARD LOOP | WEST MONROE | LA 71292
OFFICE: 318-397-3000 | FAX: 318-397-3040
SERVICE & TECH SUPPORT: 800-551-4955
SUPERLIFT.COM

High Clearance Dual Steering Stabilizer Kit 2014-2022 RAM 2500 / 3500 4WD INSTALLATION INSTRUCTIONS



INTRODUCTION

Installation requires a professional mechanic. Prior to beginning, inspect the steering sector-to-frame and all suspension-to-frame attaching points for stress cracks. The overall vehicle must be in excellent working condition; repair or replace all worn parts.

Read instructions several times before starting. Be sure you have all needed parts and know where they install. Read each step completely as you go.

NOTES:

- Prior to beginning the installation, check all parts and hardware in the box with the parts list below. If you find a packaging error, contact Superlift directly. Do not contact the dealer where the system was originally purchased. You will need the control number from each box when calling; this number is located at the bottom of the part number label and to the right of the bar code.
- A foot-pound (unless noted) torque reading is given in parenthesis () after each appropriate fastener.
- Prior to attaching components, be sure all mating surfaces are free of grit, grime, grease, undercoating, etc.
- A factory service manual should be on hand for reference.

PARTS LIST ... The part number is stamped into each part or printed on an adhesive label. Identify each part and place the appropriate mounting hardware with it.

| Kit Part Number 92712 | | | Kit Part Number 92713 | | |
|---------------------------------|------|----------------------------------|---------------------------------|------|---------------------------------|
| Part Number | Qty. | Description | Part Number | Qty. | Description |
| 55-11-92712 | 1 | Tie Rod Bracket, Driver Side | 55-11-92712 | 1 | Tie Rod Bracket, Driver Side |
| 55-12-92712 | 1 | Tie Rod Bracket, Passenger Side | 55-12-92712 | 1 | Tie Rod Bracket, Passenger Side |
| 55-13-92712 | 1 | Axle Bracket | 55-13-92712 | 1 | Axle Bracket |
| 77-92712 | 1 | Hardware Bag | 77-92712 | 1 | Hardware Bag |
| 88-92712 | 1 | Instruction Bag | 88-92712 | 1 | Instruction Bag |
| 01-81160 (658545) | 2 | Superide Stabilizer Cylinder | 02-95024 | 2 | Superide SS Stabilizer Cylinder |
| Kit Part Number 77-92712 | | | Kit Part Number 88-92712 | | |
| Part Number | Qty. | Description | Part Number | Qty. | Description |
| 12X212C5CS | 4 | 1/2" x 2-1/2" Coarse Thread Bolt | FORM#92712 | 1 | Instruction Form |
| 12UW | 4 | 1/2" USS Washer | 0046 | 2 | Decal, Superide |
| 12C8SN | 4 | 1/2" Stover Nut | 0047 | 2 | Decal, Superide SS |
| 516X2X3UB | 2 | 5/16" x 2" x 3" U-Bolt | 0082 | 1 | Decal, Circle Corporate Logo |
| 516X158X214UB | 2 | 5/16" x 1-5/8" x 2-1/4" U-Bolt | | | |
| 516FLN | 8 | 5/16" Locking Flange Nut | | | |
| 01-60450 | 4 | Sleeves | | | |

| Step | Part Number | Qty. Per Kit | Description | Qty. Per Bracket | New Attaching Hardware | Hardware Bag Number |
|------|-------------|--------------|---------------------------------|------------------|----------------------------------|---------------------|
| 6 | 55-11-92712 | 1 | Tie Rod Bracket, Driver Side | 2 | 5/16" x 2" x 3" U-Bolt | 77-92712 |
| | | | | 4 | 5/16" Locking Flange Nut | |
| 5 | 55-12-92712 | 1 | Tie Rod Bracket, Passenger Side | 2 | 5/16" x 1-5/8" x 2-1/4" U-Bolt | 77-92712 |
| | | | | 4 | 5/16" Locking Flange Nut | |
| 4 | 55-13-92712 | 1 | Axle Bracket | | Reuse Factory OEM Hardware | |
| 7 | | 2 | Steering Stabilizer Cylinder | 2 | 1/2" x 2-1/2" Coarse Thread Bolt | 77-92712 |
| | | | | 2 | 1/2" USS Washer | |
| | | | | 2 | 1/2" Stover Nut | |
| | | | | 2 | Sleeves | |

INSTALLATION

1. Make sure the tires are pointed straight forward. Place the transmission in park and chock the tires.
2. Remove the factory steering stabilizer cylinder and discard.
3. Remove the factory steering stabilizer bracket from the passenger side and discard. Remove the plate from the center of the axle.
4. Remove the factory steering stabilizer bracket (positioned off-center to the passenger side or left of the differential. Remove the four (4) bolts (two (2) in front & two (2) up from the bottom.
5. [Illustration 1] Position the center axle bracket (55-13-92712) over the four holes on the axle and loosely attach using the factory hardware.
6. Push the center axle bracket up and away from the tie rod to create at least 1/2" of clearance between the bracket and tie rod, then tighten the bottom two bolts followed by the top two. (23)
7. [Illustration 1] Position the passenger side tie rod bracket (55-12-92712) as shown, secure using the supplied 5/16 x 2" x 3" ubolts front-to-rear over factory tie rod and through the bracket. There is a slight depression in the top of the tie rod end that the inner most ubolt should be positioned over. Install 5/16" locking flange nuts, snug but do not tighten.
8. [Illustration 1] Position the driver side tie rod bracket (55-11-92712) as shown, secure using the supplied 5/16 x 1-5/8" x 2-1/4" ubolts front-to-rear over factory tie rod and through the bracket. The inner most ubolt should be approximately 2-1/4" from the end of the outer tie rod sleeve. Install 5/16" locking flange nuts, snug but do not tighten.
9. [Illustration 1] Insert sleeves into cylinders. Install the steering stabilizers with the cylinder body to the inside of the vehicle as shown. Attach the cylinders to the bottom of the center bracket with the supplied 1/2" x 2-1/2" bolts inserted from the bottom up (bolt, washer, cylinder, bracket & stover nut). Then attach the cylinder rod eye underneath the driver side bracket, using the supplied 1/2" hardware. Next attach the cylinder rod eye underneath the passenger side bracket, using the supplied 1/2" hardware. Once in position, tighten the 5/16" u-bolts securely. (16.5)
10. Have an assistant cycle the steering lock to lock as you observe the operation of the steering stabilizers. Verify that the steering operates smoothly and that the stabilizers do not "bottom out," preventing the steering from operating through its full cycle. If either one of the stabilizers bottoms out, it may be necessary to adjust the position of the tie rod bracket until the necessary clearance is achieved.
11. Also during the steering cycle, check clearance between the stabilizer bodies and the rest of the steering components. Check to make sure all steering components are operating properly without any bind. Double-check all fasteners for proper tightness and adequate clearance.

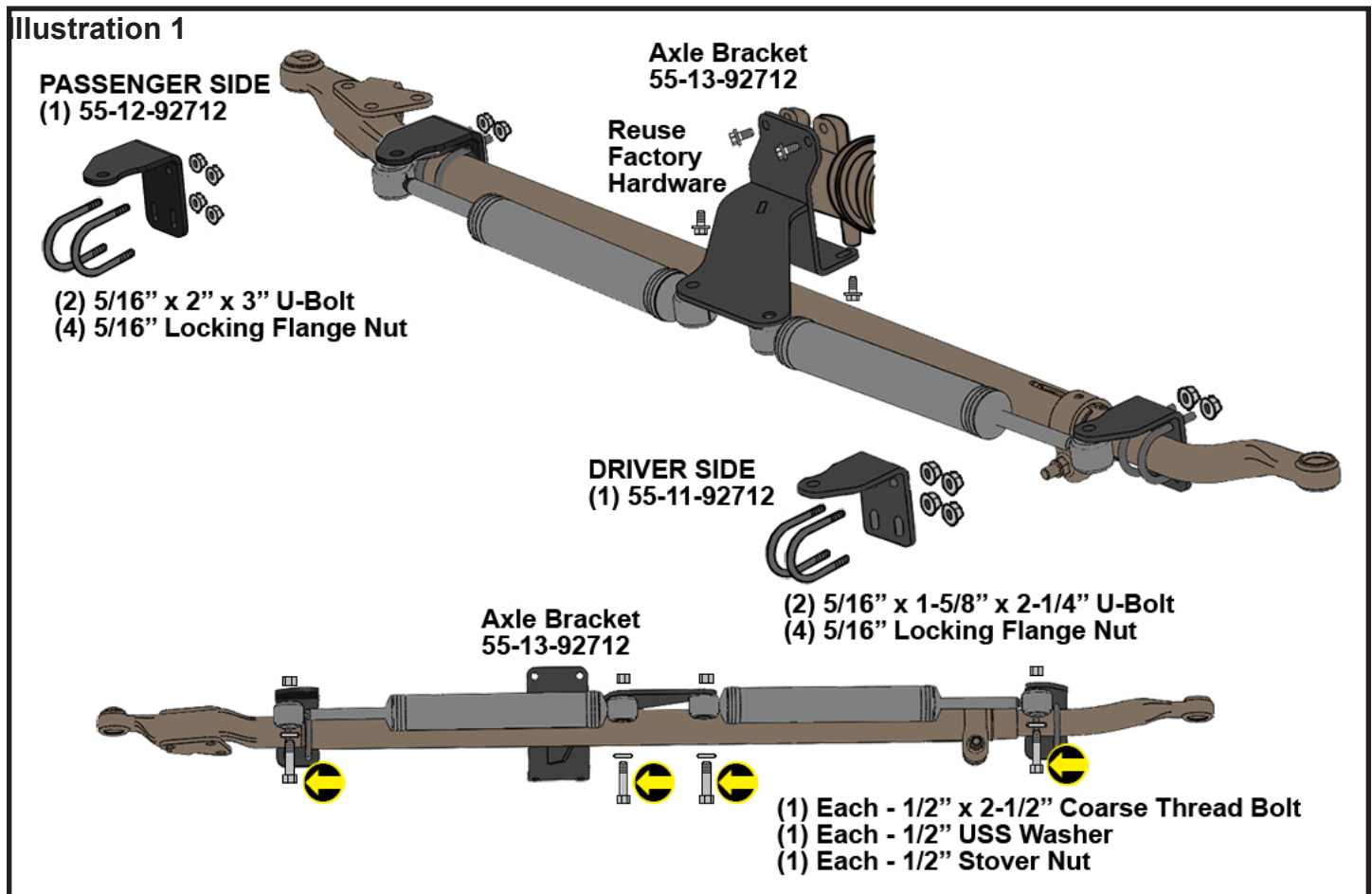
Illustration 1**Important Maintenance Information**

It is the ultimate buyer's responsibility to have all bolts / nuts checked for tightness after the first 100 miles and then every 1000 miles. The steering, suspension and driveline systems, plus wheel alignment should be inspected by a qualified professional mechanic at least every 3000 miles.

Limited Lifetime Warranty / Warnings

Your SUPERLIFT® product is covered by the Limited Warranty explained below that gives you specific legal rights. This limited warranty is the only warranty SUPERLIFT® makes in connection with your product purchase. SUPERLIFT® neither assumes nor authorizes any retailer or other person or entity to assume for it any other obligation or liability in connection with this product or limited warranty.

Superlift, LLC, Limited Lifetime Warranty

What is covered? Subject to the terms below, SUPERLIFT® will repair or replace its products found defective in materials or workmanship for so long as the original purchaser owns the vehicle on which the product was originally installed. Your warrantor is SUPERLIFT, LLC, doing business as Superlift® Suspension Systems ("SUPERLIFT®").

What is not covered? Your SUPERLIFT® Limited Warranty does not cover products SUPERLIFT® determines to have been damaged by or subjected to:

- Alteration, modification or failure to maintain.
- Normal wear and tear (bushings, rod ends, etc.). Scratches or defects in product finishes (powder coating, plating, etc.).
- Damage to, or resulting from, the vehicle's electronic stability system, related components or other vehicle systems.
- Racing or other vehicle competitions or contests. Accidents, impact by rocks, trees, obstacles or other aspects of the environment.
- Theft, vandalism or other intentional damage.

Remedy Limited to Repair or Replacement. The exclusive remedy provided hereunder shall, upon Superlift's inspection and at Superlift's option, be either repair or replacement of the product covered under this Limited Warranty. Customers requesting warranty consideration should contact SUPERLIFT® by phone (1-800-551-4955) to obtain a Returned Goods Authorization number. All removal, shipping and installation costs are customer's responsibility.

If a replacement part is needed before the SUPERLIFT® part in question can be returned, you must first purchase the replacement part. Then, if the part in question is deemed warrantable, you will be credited / refunded.

Other Limitations - Exclusion of Damages - Your Rights Under State Law

- Neither SUPERLIFT® nor your independent SUPERLIFT® dealer are responsible for any time loss, rental costs, or for any incidental, consequential or other damages you may have.
- This Limited Warranty gives you specific rights, and this is the only warranty SUPERLIFT® makes in connection with your product purchase. You may also have other rights that vary from state to state. For example, while all implied warranties are disclaimed herein, any implied warranty required by law is limited to the terms of our Limited Lifetime Warranty as described above. Some states do not allow limitations of how long an implied warranty lasts and / or do not allow the exclusion or limitation of incidental or consequential damages, so the limitations and exclusions herein may not apply to you. SUPERLIFT® neither assumes nor authorizes any retailer or other person or entity to assume for it any other obligation or liability in connection with this product or Limited Warranty.

Superlift, LLC, Satisfaction Guarantee

We want you to purchase our product with confidence and be 100% satisfied with the end result. If you have any legitimate issue, and SUPERLIFT® cannot rectify it to your satisfaction, SUPERLIFT® will take back the SUPERLIFT® brand product and refund the customer 100% of the product purchase price.

The details:

- Offer valid to the original retail consumer for six months after product purchase.
- May require a SUPERLIFT® dealer's participation in order to assist in "troubleshooting" the issue.
- Any costs related to labor, freight, incidental or consequential are not refunded.
- Refund will not exceed SUPERLIFT's published retail price.

Important Product Use and Safety Information / Warnings

As a general rule, the taller a vehicle is, the easier it will roll over. Offset, as much as possible, what is lost in rollover resistance by increasing tire track width. In other words, go “wide” as you go “tall”; always use as wide a tire and wheel combination as feasible to enhance vehicle stability. We strongly recommend, because of rollover possibility, that the vehicle be equipped with a functional roll bar and cage system. Seat belts and shoulder harnesses should be worn at all times. Avoid situations where a side rollover may occur.

Generally, braking performance and capabilities are decreased when significantly larger / heavier tires and wheels are used. Take this into consideration while driving. Also, changing axle gear ratios or using tires that are taller or shorter than factory height will cause an erroneous speedometer reading. On vehicles equipped with an electronic speedometer, the speed signal impacts other important functions as well. Speedometer recalibration for both mechanical and electronic types is highly recommended.

Do not add, alter, or fabricate any factory or aftermarket parts to increase vehicle height over the intended height of the SUPERLIFT® product purchased. Mixing component brands is not recommended.

SUPERLIFT LLC
300 Huey Lenard Loop Road
West Monroe, Louisiana 71292
Phone: (318) 397-3000
Sales / Tech: (800) 551-4955
Fax: (318) 397-3040
www.superlift.com